

### Application

Volumetric feeding of free flowing to very poorly flowing powders (e.g. lumpy, moist or bridge building materials) as well as fibers, flakes and other bulk materials. The feeder can be upgraded to a loss-in-weight feeder system at any time.

### Design

Twin screw feeder with interchangeable feeding tools. All parts in contact with the material being fed are stainless steel. Feeding equipment is easy to disassemble. The horizontal agitator gently moves the bulk material to the large throat and then into the screws. Feeder screws are easily interchangeable.

This equipment conforms to CE standards regarding EMC and safety.

**Controller:** (see separate data sheets)

The SmartConnex® control system allows individual or multi-component control. Each feeder has its own control module. Connection between feeders, operator interface and smart I/O is via an industrial network. A variety of protocols is available for connection to the plant's host system.

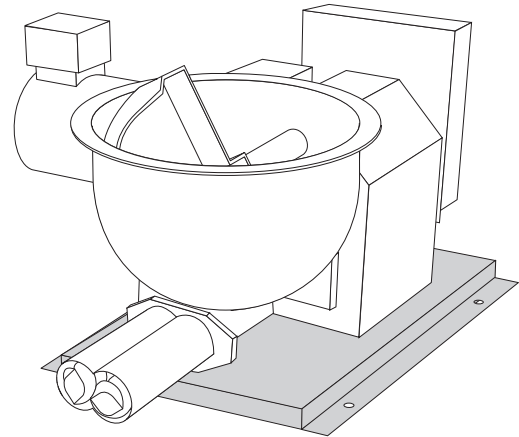

**Hazardous Location Options:** (see sheet I-000002)

- NEC Class II, Div. 2, Groups F & G / Class II, Div. 1, Groups F & G  
 Class I, Div. 2, Groups C & D / Class I, Div. 1, Groups C & D
- ATEX 3D/3D, 3D/2D, 3G/3G, 2GD/2GD (outside/inside)

### Feed Screws and Feed Rates

Actual feeder screws are determined based on the material being fed.

**Attention:** The following rates are theoretical values for free flowing materials being fed volumetrically. Actual feed rates depend on individual material characteristics. The feed range for loss-in-weight feeders is somewhat smaller. For feed rates at the upper or lower limits of the theoretical range, check with a K-Tron Test Lab.

Pitch	Type of drive	Twin concave screws		Twin auger screws		Double auger screws		Speed range	Gearbox type
		dm³/h	ft³/h	dm³/h	ft³/h	dm³/h	ft³/h		
coarse pitch	⊖	16 - 1611	0.57 - 56.9	17 - 1673	0.6 - 59.1	7 - 715	0.25 - 25.5	6 - 621	A
		7.7 - 772	0.3 - 27.3	8.0 - 807	0.3 - 28.5	3 - 346	0.11 - 12.2	3 - 297	B
		3.3 - 334	0.1 - 11.8	3.5 - 347	0.1 - 12.3	4 - 184	0.07 - 6.5	1.3 - 128	C
	⊕	113 - 1965	4 - 69.4	117 - 2041	4.1 - 72.1	50 - 870	1.77 - 30.7	43 - 756	A
		54 - 942	1.9 - 33.3	56 - 978	2 - 34.5	21 - 421	0.74 - 14.87	21 - 362	B
		23 - 407	0.8 - 14.4	24 - 423	0.9 - 14.9	14 - 225	0.49 - 7.9	9 - 157	C
fine pitch	⊖	5.6 - 558	0.2 - 19.7	11 - 1130	0.39 - 40	5 - 497	0.18 - 17.6	6 - 621	A
		2.7 - 267	0.09 - 9.4	5 - 510	0.18 - 18	2 - 240	0.07 - 8.5	3 - 297	B
		1.2 - 116	0.04 - 4.1	2 - 190	0.071 - 6.7	2 - 128	0.07 - 4.5	1.3 - 128	C
	⊕	39 - 680	1.4 - 24	67 - 1130	2.4 - 40	35 - 605	1.24 - 21.4	43 - 756	A
		19 - 326	0.8 - 11.5	32 - 635	1.1 - 23	14 - 292	0.49 - 10.3	21 - 362	B
		8.1 - 141	0.3 - 5	14 - 237	0.49 - 8.4	14 - 157	0.49 - 5.5	9 - 157	C

⊖ DC-motor with speed controller / Range 1 : 100 / Max. motor speed 2000 RPM  
 ⊕ AC-motor with frequency inverter / Range 1 : 17 / Max. motor speed 2440 RPM /  
 NOTE: For US applications the AC motor range is 1:12 with max. motor speed of 1725

### Configuration

Description	Selection	Remarks	Weight kg (lb)
Vertical agitator	KS: 230/400 VAC 0.18, 0.25 kW IP55	4D (50 L, 80 L) 6D (110 L, 180 L)	25 (55) 36 (79)
Cover	KA: 115/230 VAC 0.25, 0.33 HP or 100/200 VDC 0.33 HP	2D 4D 6D	1 (2) 2 (4.4) 3 (6.6)
Extension hopper		2D, 4D or 6D	see below
Horiz. agitator			0.7 (1.5)
Trough	5 L		2.5 (5.5)
Gearbox	A B C		15 (33)
Motor	100 or 200 VDC 0.45 kW IP 65	3 phase AC freq. inverter KS: 230/400 V KA: 230/460 V 0.55 kW, IP 55	standard: 0.45 kW 12 (26.4)
Screws		see page 1	2 (4.4)
Outlet	Horiz. outlet Vertical outlet Pressure compensation	standard: horiz. outlet	1 (2.2)

#### Materials:

Material contact parts\*: Stainless steel  
 DIN 1.4404, 1.4435 (AISI 316L)  
 DIN 1.4409 (ASTM A743 CF3M)  
 \*Horiz. agitator: DIN 1.4034 (AISI 420) standard  
 DIN 1.4404 (AISI 316L) option  
 Seals: PTFE, Neoprene, Silicone  
 Painting: Light grey RAL 7035

#### Temperature-Limits:

Ambient: 0 to 40.5 °C (32 to 105°F)  
 Material: standard: -20 to 55 °C (-4 to 130 °F)  
 option: -15 to 150 °C (0 to 300 °F)

### Dimensions mm (in)

A: Baseplate dimensions for European units  
 B: Baseplate dimensions for US units

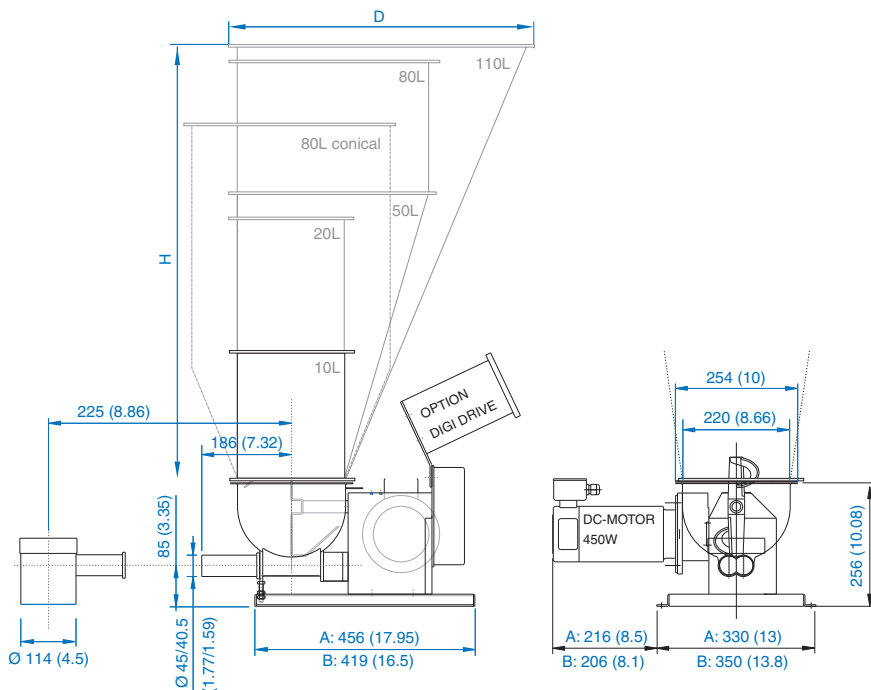

### Options

- 1 Hopper
- 2 Frame
- 3 Vertical outlet
- 4 Special paint
- 5 Extended screws

#### Asymmetrical Hoppers

Volume dm <sup>3</sup> (ft <sup>3</sup> )	H mm (in)	D1 mm (in)	Weight kg (lb)
50 (1.8)	615 (24.2)	400 (15.7)	7 (15.4)
80 (2.8)	869 (34.2)	400 (15.7)	11 (24.2)
110 (3.9)	922 (36.3)	600 (23.6)	17 (37.4)
180 (6.4)	1176 (46.3)	600 (23.6)	23 (50.6)
320 (11.3)	1684 (66.3)	600 (23.6)	35 (77)

#### Symmetrical Hoppers

10 (0.35)	283 (11)	220 (8.7)	3 (6.6)
20 (0.71)	566 (22.3)	220 (8.7)	6 (13.2)
80 (2.8)	727 (28.6)	400 (15.7)	11 (24.6)
180 (6.4)	889 (35)	600 (23.6)	23 (50.6)

**Caution:** these measurements are for general reference only. Please consult dimensional drawing for exact measurements