

HOMILOID®

Small Scale
Wet or Dry
Size Reduction



FITZ®MILL

VERSATILE SIZE REDUCTION

The Homiloid® can be utilized to meet all of your small scale size reduction requirements.

WET MILLING

The Homiloid® has been incorporated into the following wet applications:

- Size reduction of wet massed particles
- Smoothing of ointments and dispersion of solids into liquids
- Production of stable emulsions at high efficiency and capacities.

DRY MILLING

- Pulverizing of granular products to fine powders.
- Coarse granulating to achieve a free flowing granule with minimal dust.
- Delumping of agglomerated powders or granules.

BENEFITS

- Process batch sizes from 1/2 kg. to 50 kg.
- Liquids/solids processing
- Minimal floor space requirement
- Easily disassembled and cleaned
- All product contact parts constructed of stainless steel

**THE
FITZPATRICK
COMPANY**

SPECIFICATIONS

HOMIROID®...Small Scale Wet or Dry Size Reduction

- Gravity (dry products) or pump feed (liquid) designs
- Various blade configurations to pulverize, coarse grind, puree, and emulsify
- Variable rotor speeds
- Wide assortment of screens to vary granulation size
- All stainless steel contact parts
- Quick disassembly for easy cleaning

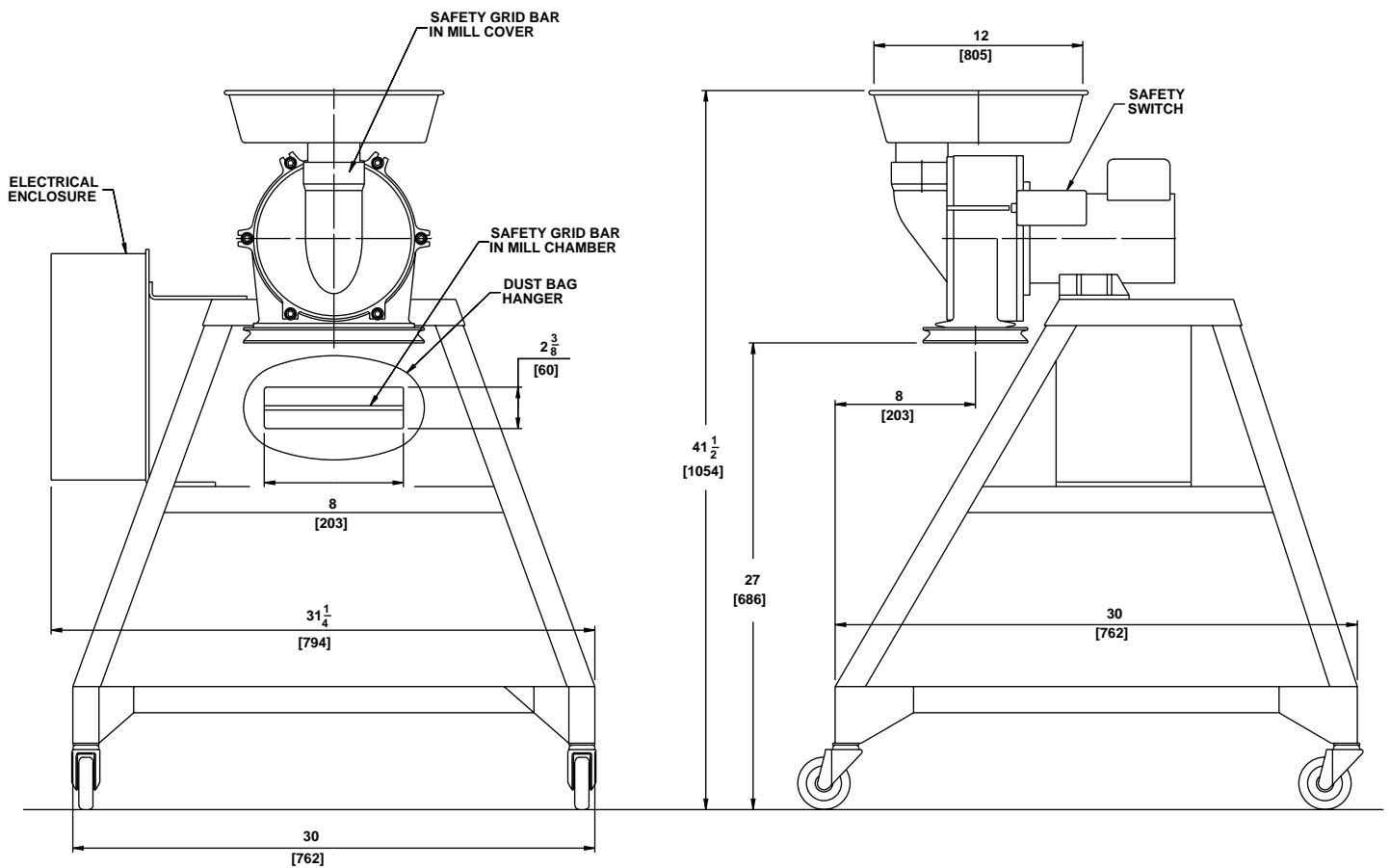

Dimensions indicated $\frac{\text{inches}}{\text{[millimeters]}}$

FITZPATRICK®

CUTTING EDGE SOLUTIONS...IN SMALL SCALE SIZE REDUCTION

CORPORATE HEADQUARTERS

832 Industrial Drive
Elmhurst, IL 60126
Phone: 630-530-3333
Fax: 630-530-0832
E-mail: info@fitzmill.com
www.fitzmill.com

EASTERN DIVISION

4219 S. Clinton Ave.
South Plainfield, NJ 07080
Phone: 908-561-1500
Fax: 908-561-9636
E-mail: info_nj@fitzmill.com

FITZPATRICK EUROPE N.V.

Entrepotstraat 8
B-9100 Sint-Niklaas, Belgium
Phone: 32-3-777-7208
Fax: 03-766-1084
E-mail: info@fitzpatrick.be
www.fitzpatrick.be